

Driveway/Approach Addition Requirements

- THE CITY OF GRIMES IS NOT RESPONSIBLE FOR ESTABLISHING PROPERTY LINES.
- AN APPROVED PERMIT IS REQUIRED FOR ALL DRIVEWAY ADDITIONS **IF** YOU ARE DOING WORK IN CITY RIGHT OF WAY OR INCREASING THE SIZE OF YOUR APPROACH
- A CONCRETE APPROACH IS REQUIRED TO BE 6" THICK
- AN INSPECTION IS REQUIRED PRIOR TO POURING A CONCRETE APPROACH
- SAND IS NOT ALLOWED FOR BASE, IT MUST BE COMPACTED DIRT OR ROCK IN THE CITY RIGHT OF WAY
- AN EXPANSION JOINT MUST BE INSTALLED AT THE STREET AND THE SIDEWALK.
- YOU DO NOT NEED A PERMIT IF ALL THE WORK IS ON PRIVATE PROPERTY
- THE MAXIMUM WIDTH OF A DRIVEWAY IN AN "R" DISTRICT IS 24'
- THE MAXIMUM WIDTH AT THE CURB OPENING IS 34'
- 3-5 FOOT FLARES REQUIRED PER SIDE OF APPROACH
- THE DRIVEWAY AND CURB OPENING PROPORTION RATIO HAS TO BE MET. YOU CANNOT INCREASE ONE WITHOUT INCREASING THE OTHER. EXAMPLES ARE ON THE BACK OF THIS SHEET.
- THE PERMIT FEE FOR INCREASING DRIVEWAYS/APPROACHES IN CITY RIGHT OF WAY IS \$30

Exception – the driveway may be extended on the private side by 2 ft on one side, for a maximum width of 26 ft at the sidewalk. **** NEW ****

See page 2 for examples.

-YOU ARE ENCOURAGED TO DISCUSS YOUR PROJECT WITH THE BUILDING ADMINISTRATOR OR BUILDING INSPECTOR.

HELP US, HELP YOU. IF YOU HAVE ANY QUESTION OR NEED FURTHER CLARIFICATION, CONTACT THE BUILDING ADMINISTRATOR OR BUILDING INSPECTOR AT 515-986-3036

DRIVEWAY; THE PAVED AREA ON PRIVATE PROPERTY

APPROACH; THE PAVED AREA BETWEEN THE STREET AND SIDEWALK OR PROPERTY LINE

DRIVEWAY WIDTH
10'-0" MIN., 24'-0" MAX. (LOCAL/COLLECTOR):

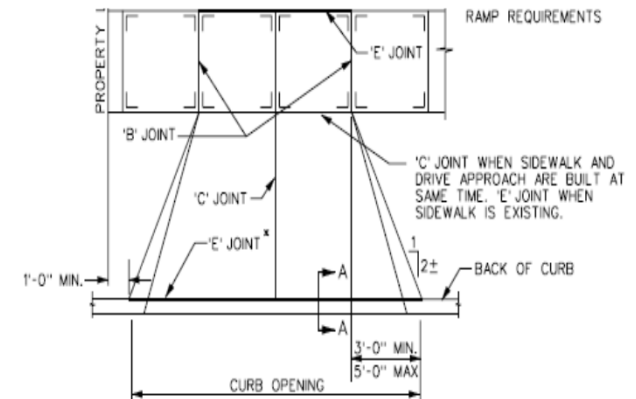

Iowa law requires you to call Iowa One Call 48 hours previous to any digging



**Call Before You Dig!
1-800-292-8989**

Notification service for locating underground

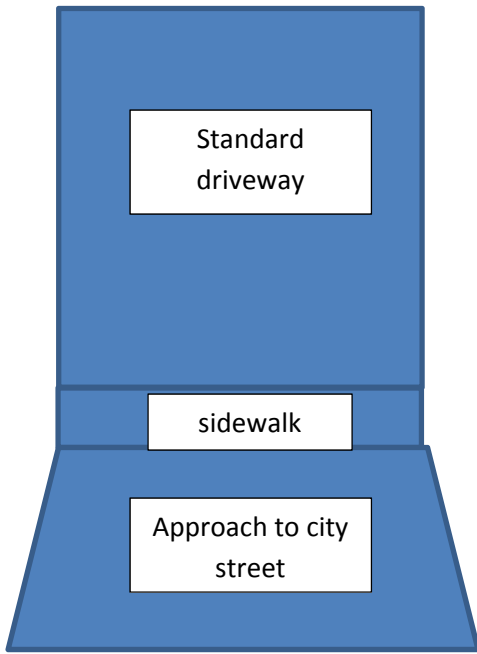

Standard Approach:

Max at top: 24 ft

Max at street: 34 ft

Minimum flare at street: 3 ft

Maximum flare at street: 5 ft

